

**SANT NIRANKARI PUBLIC SCHOOL, TILAK NAGAR**

**ASSIGNMENT**

**SUBJECT: ENGLISH**

**TOPIC: SENTENCES**

**DAY: 1**

1. Identify the type of sentences as declarative, interrogative, imperative, explanatory and negative sentences:
  - a. English is my favourite subject.
  - b. Oh! You drive me crazy.
  - c. Do you service electronic goods?
  - d. I am not your friend.
  - e. You should use the elevator.
  - f. I love my home.
  - g. How amazing is! The Niagara Waterfall.
  - h. Could you pass me that wonderful sauce?
  - i. I don't like to have pets.
  - j. You have to take a blood test immediately.
2. Rewrite the jumbled words to make meaningful sentences:
  - a. Should/ positive/ you/have/ thoughts/ always
  - b. Confidence/ never/ yourself/ in/ lose
  - c. Teachers/ to/ parents/ thankful/ your/ be/ and/ you/ should
  - d. Live/ learn/ to/ nature/ with
  - e. Treasure/ life/ enjoy/ is/a/ to
3. Change these sentences into negative sentences:
  - a. He is an honest man.
  - b. She is always on time.
  - c. Everyone liked the lecture.
  - d. He is sure of his success.
  - e. The water is too cold to drink.
  - f. Everybody is present.
  - g. I found the film interesting.

**SANT NIRANKARI PUBLIC SCHOOL, TILAK NAGAR**

**ASSIGNMENT**

**SUBJECT: ENGLISH**

**TOPIC : SUBJECT AND PREDICATE**

**DAY:2**

1. Circle the subject and underline the predicate in each of the following sentences
  - a. Small cars sell more than big ones.
  - b. The boat rocked in the stormy seas.
  - c. The village folk gathered at the Community hall.
  - d. The playground was maintained well by the youth.
  - e. The table was set for four.
  - f. Thee child has written an essay on Diwali Celebration.
  - g. Lions chased the deer for their food.
  - h. Africa is rich in natural resources.
2. Complete the following subjects with interesting predicates:
  - a. Our school principal \_\_\_\_\_
  - b. Maria \_\_\_\_\_
  - c. The school bell \_\_\_\_\_
  - d. The class \_\_\_\_\_
  - e. The sun \_\_\_\_\_
  - f. The old man \_\_\_\_\_
  - g. The kittens \_\_\_\_\_
  - h. The book \_\_\_\_\_
3. Join each subject with the correct predicate:
  - a. The shepherd                      has written a novel for kids.
  - b. The earth                            were very difficult.
  - c. The author                          minds his sheep.
  - d. Walking                              revolves around the sun.
  - e. The exams                            is chasing a mouse.
  - f. A cat                                    is a good physical exercise.

**SANT NIRANKARI PUBLIC SCHOOL, TILAK NAGAR**

**ASSIGNMENT**

**SUBJECT: ENGLISH**

**TOPIC: NOUNS**

**DAY:3**

1. A. Find out the nouns in the following sentences and write them under the correct columns:
  - a. My dog had a litter of puppies.
  - b. The team played well and won the match.
  - c. The contest was won by the girls from our school.
  - d. The crowd demonstrated at M G Road.
  - e. We saw many tigers at the sanctuary.
  - f. Monica got an award for her bravery.
  - g. Sheetal and Zubby went to a party on Friday.

B. Write the nouns in the following columns:

PROPER NOUNS  
COMMON NOUNS  
COLLECTIVE NOUNS  
ABSTRACT NOUNS
2. Fill in the blanks with correct options given in the brackets:
  - a. The \_\_\_\_\_ of musicians were also appreciated. ( heap/ band)
  - b. The \_\_\_\_\_ gave a standing ovation to the singer. ( audience/ herd)
  - c. A \_\_\_\_\_ of students were attacked by a \_\_\_\_\_ of boys. ( gang/ pile/ class)
  - d. The \_\_\_\_\_ of players wore blue jerseys. ( Team/ crowd)
  - e. The church \_\_\_\_\_ sang hymns in our meeting. ( bouquet/ choir)
3. Give the abstract nouns for the following adjectives:
  - a. Successful
  - b. Young
  - c. Childish
  - d. Deep
  - e. Sympathetic
  - f. Angry
  - g. Egoistic
  - h. Jealous

**SANT NIRANKARI PUBLIC SCHOOL, TILAK NAGAR**

**ASSIGNMENT**

**SUBJECT: ENGLISH**

**TOPIC: GENDER**

**DAY:4**

1. Change the gender:
  - a. Cow
  - b. Deer
  - c. Peahen
  - d. Wizard
  - e. Master
  - f. Prince
  - g. Actor
  - h. Lion
  - i. Fox
  - j. Daughter
2. Rewrite these sentences after changing the gender of the underlined nouns:
  - a. The girl is more talkative than her mother.
  - b. There are many drakes in the pond.
  - c. My sister works as a waitress.
  - d. The tigress attacked the horse.
  - e. The bride was blessed by the priest.
  - f. The boy wants to become an emperor.
  - g. The mother-in-law arrived with her uncle.
  - h. We pray to God every day.
  - i. The man played the role of queen.
3. Identify the gender of these nouns. Mark M for masculine, F for feminine, C for common and N for neuter.
  - a. Waiter
  - b. Friend
  - c. Father
  - d. Bull
  - e. House
  - f. Relatives
  - g. Hostess
  - h. Heroine
  - i. Brother
  - j. Mountain
  - k. Shepherd
  - l. Mayor

**SANT NIRANKARI PUBLIC SCHOOL, TILAK NAGAR**

**ASSIGNMENT**

**SUBJECT: ENGLISH**

**TOPIC: SINGULAR & PLURAL**

**DAY: 5**

1. Write the plural for these nouns:
  - a. Box
  - b. Tooth
  - c. Strawberry
  - d. Woman
  - e. Child
  - f. City
  - g. Person
  - h. Leaf
  - i. Tomato
  - j. Fairy
  - k. Match
  - l. Bird
  - m. Key
  - n. Goose
  - o. Knife
2. Rewrite the following sentences with the plural or singular forms of the nouns:
  - a. The cycle at the shop was expensive.
  - b. Wolves were howling at night.
  - c. The thief ran away with the loot.
  - d. The monkeys were swinging on the branches of the trees.
  - e. The juggler did a show with a spoon.
  - f. There is a mouse in the house.
3. Underline the nouns and mention whether they are countable (C) or uncountable (U) nouns:
  - a. Please add some salt to my food.
  - b. There is smoke in the room.
  - c. A few cupcakes were left.
  - d. I love eating dosas with sambhar and chutney.
  - e. The waste from the factories pollute our rivers.
  - f. I have read all the books.
  - g. The tables of the office are broken and the floor is dirty.
  - h. We must save water.

**SANT NIRANKARI PUBLIC SCHOOL, TILAK NAGAR**

**ASSIGNMENT**

**SUBJECT: ENGLISH**

**TOPIC: ARTICLES**

**DAY: 6**

1. Fill in the blanks with a, an or the. Mark a cross(x) where no article is required:
  - a. Kavita is \_\_\_\_ nice girl.
  - b. Do you like \_\_\_\_ rock music?
  - c. She works in \_\_\_\_ factory.
  - d. We are going to \_\_\_\_ United Kingdom in \_\_\_\_ June.
  - e. I borrowed \_\_\_\_ pen from \_\_\_\_ someone.
  - f. This is \_\_\_\_ man Rahul was talking about.
  - g. Rani went to China and saw \_\_\_\_ Great Wall of China.
  - h. I will meet you at \_\_\_\_ restaurant that opened on \_\_\_\_ Sunday.
  - i. We need \_\_\_\_ engineer to fix the fault in the meter.
  - j. Don't forget to post \_\_\_\_ letters I gave you.
2. Tick the right article to complete the sentence:
  - a. Will you watch a/ an/the English film with me?
  - b. I bought a/an/the egg to make a/an/ the toast.
  - c. We had a/ an/ the exciting tour in a/ an/ the Alps.
  - d. He attended a/ an / the interview but did not get a/ an/ the job.
  - e. There was a/an/the said and a/ an/the octopus at a/ an/ the show.
3. Use a suitable article. Ignore if there is no need of an article:

I study in a/ an/ the best school in the city. It has a/ an/ the beautiful garden and a/an/the excellent library. We have a/ an/the assembly every morning when the students take a/ an/ the school pledge. We then March to our class where a/an/the teacher begins lessons for a/ an/ the day. During lunch interval, we have some time for a/an/ the chat. After a/an/the afternoon session, we leave a/ an/the school and walk a/ an/ the home.

**SANT NIRANKARI PUBLIC SCHOOL, TILAK NAGAR**

**ASSIGNMENT**

**SUBJECT : ENGLISH**

**TOPIC: ADJECTIVES**

**DAY: 7**

1. Underline the adjectives in these sentences:
  - a. Rajiv is an intelligent boy.
  - b. Do you see my shoes?
  - c. This dress is mine.
  - d. I have a free bananas to feed the monkeys.
  - e. I had two sandwiches in the morning.
  - f. He is a brave soldier.
  - g. The tree bears delicious mangoes.
  - h. My mother bought a pretty dress for me.
  - i. The little girl gave a few nuts to the naughty monkey.
  - j. Our apartment has two lifts.
2. Fill in the blanks with an interesting adjective:
  - a. Nisha is wearing a \_\_\_\_\_ skirt; she looks \_\_\_\_\_.
  - b. He provides food for \_\_\_\_\_ people living on platforms.
  - c. She adopted a \_\_\_\_\_ cat from the \_\_\_\_\_ street.
  - d. Her argument is \_\_\_\_\_. It is a waste of my \_\_\_\_\_ time.
  - e. This food is not \_\_\_\_\_ ; the person who prepared is not a \_\_\_\_\_ cook.
3. Complete the table:

Positive	Comparative	Superlative
Fast		
	Higher	
		Softest
Good		
	Smaller	
		Most beautiful
Old		
	Easier	
		Hottest
	Heavier	
Long		

**SANT NIRANKARI PUBLIC SCHOOL, TILAK NAGAR**

**ASSIGNMENT**

**SUBJECT: ENGLISH**

**TOPIC: PREPOSITIONS**

**DAY: 8**

1. Strike out the words which are not prepositions:  
Over by under mouse above chair in out river beside from by  
at noise behind on the down around within cloth across upon  
tree near after
2. Underline the prepositions in the following sentences:
  - a. Mother hid the bottle under the bed.
  - b. The old man leaned against the tree.
  - c. Birds build nests on branches.
  - d. The jogger ran along the seashore.
  - e. The mouse hid behind the bag of coins.
  - f. Potatoes grow under the ground.
  - g. The boy jumped off the wall.
  - h. I have never heard of him before.
  - i. They climbed over the fence and went into the garden next door.
  - j. The cat looked down from the shelf.
  - k. I walked to the shop.
  - l. Why don't you wait outside the office?
  - m. Please collect all the books and place them on the table.
  - n. The pilgrims went to the bank of the Ganges for a dip in the holy river.
  - o. We walked up the slope to the top of the hill.
3. Circle the prepositions in the passage:  
Abu and Abhi went on a trip to a zoo in an island. They had to go across a narrow bridge to reach it because water was flowing around the zoo. They climbed into a boat and were seated on the benches provided. It was breezy and cold, so Abhi put a shawl around her shoulders. Abu sat with her legs tucked under her because the floor was wet. When they reached the zoo, they jumped out of the boat and walked towards the cages where parrots were perched on the branches and the monkeys were swinging on the trees.



**SANT NIRANKARI PUBLIC SCHOOL, TILAK NAGAR**

**ASSIGNMENT**

**SUBJECT: ENGLISH**

**TOPIC: PUNCTUATION**

**DAY: 9**

1. Correct the errors in the use of punctuation and capital letters:
  - a. saturday
  - b. mr. wilson
  - c. the red fort
  - d. wont
  - e. marthas home
2. Rewrite the poem with proper punctuation marks:

don't think about a zebra  
whatever you do  
for if you think of one  
then you will have to think of a herd  
oh what a shame  
it would be  
if your mother sees  
zebras in your mind  
not homework oh
3. Punctuate the following sentences:
  - a. please assemble here
  - b. are you in a hurry please wait
  - c. my god what a mess who did this
  - d. if I catch the culprit I will punish him severely
  - e. there is no reason is there
  - f. wonderful thats very good news
  - g. do you know the name of the smallest country in the world
  - h. the air India flight from london lands in delhi at 11.55 am
  - i. the macaw is a large brightly coloured bird found mostly in rainforests
  - j. how dare you speak to her like that
  - k. when you go the mall please buy fruits vegetables eggs and butter
  - l. the soldiers have been living in camps for many months

**SANT NIRANKARI PUBLIC SCHOOL, TILAK NAGAR**

**ASSIGNMENT**

**SUBJECT: ENGLISH**

**TOPIC: PARAGRAPH & LETTER WRITING**

**DAY: 10**

1. Write a paragraph on the topic ' My Grandparents'.
2. Write a paragraph on the topic ' Importance of Trees'.
3. Write a paragraph on the topic 'My Pet Dog'.
4. Write a leave application to the Principal of your school.

**SANT NIRANKARI PUBLIC SCHOOL, TILAK NAGAR**  
**ENVIRONMENTAL STUDIES**  
**SESSION 2020-2021**  
**CLASS-IV**  
**CHAPTER-GOING TO SCHOOL**  
**Assignment-1(MONTH-APRIL)**

**Q1.** Choose the correct answer.

- i. It rains so much here \_\_\_\_\_.
  - a. Assam
  - b. Rajasthan
- ii. \_\_\_\_\_ is an open box made of wood.
  - a. Trolley
  - b. Pulley
- iii. Which of the following is not a modern mean of transport?
  - a. Aeroplane
  - b. Cart
- iv. \_\_\_\_\_ is used in Rajasthan.
  - a. Camel cart
  - b. Bike

**Q2.** Fill in the blanks.

- i. In \_\_\_\_\_, there is sand all around.
- ii. A \_\_\_\_\_ helps the trolley to move across the rope.
- iii. There is a strong \_\_\_\_\_ rope across the river.
- iv. When the snow is frozen, we may \_\_\_\_\_ and \_\_\_\_\_.

**Q3.** Match the following"-

- |                |              |
|----------------|--------------|
| i. Rope bridge | a. Kashmir   |
| ii. Snow path  | b. Karnataka |
| iii. Vallam    | c. Assam     |
| iv. Jugad      | d. Ladakh    |
| v. Trolley     | e. Kerala    |

**Q4.** Answer the following in 20-30 words.

- i. What materials are used in a cement bridge?
- ii. Write any two ways to travel on water.
- iii. What is a jugad?

**Q5.** Answer the following in 50-60 words.

- i. Write any three differences between Bamboo Bridge and cement bridge.
- ii. Draw any two modes of transport.
- iii. Write about your dream school.

**SANT NIRANKARI PUBLIC SCHOOL, TILAK NAGAR**  
**ENVIRONMENTAL STUDIES**  
**SESSION 2020-2021**  
**CLASS-IV**  
**CHAPTER-GOING TO SCHOOL**  
**Assignment-2(MONTH-APRIL)**

**Q1.** Write the names of places with the help of the clues given below:-

Clues

Places

- |      |                            |       |
|------|----------------------------|-------|
| i.   | Camel carts are used       | _____ |
| ii.  | Paths are rocky and uneven | _____ |
| iii. | Small boats are used       | _____ |
| iv.  | Our feet sink into it      | _____ |

**Q2.** Rearrange the letters to write the correct names of bridges.

- |      |          |       |        |
|------|----------|-------|--------|
| i.   | EENCTH : | _____ | bridge |
| ii.  | EPRO :   | _____ | bridge |
| iii. | OBOBMA : | _____ | bridge |

**Q3.** Fill in the blanks:-

- i. \_\_\_\_\_ Dose not pass through very thick forests.
- ii. Some bridges may also have \_\_\_\_\_.
- iii. Bullock carts are used in villages in the \_\_\_\_\_.
- iv. \_\_\_\_\_ has made it easy for girls to go to school in many parts of our country.

**Q4.** Answer the following questions in 20-30 words.

- i. How many people do you think can cross the bridge at one time.
- ii. Which is the best month, in which you like to go school? Why?
- iii. Do you think that there should be punishment in school?

**Q5.** Answer the following questions in 50-60 words.

- i. Write four lines on the topic jungle.
- ii. Make a drawing of the cart.
- iii. Is punishment the only solution to misdeeds. Frame some rules for school that avoid misdeed without punishments.

**SANT NIRANKARI PUBLIC SCHOOL, TILAK NAGAR**  
**ENVIRONMENTAL STUDIES**  
**SESSION 2020-2021**  
**CLASS-IV**  
**CHAPTER-A DAY WITH NANDU**  
**Assignment-3(MONTH-APRIL)**

**Q1.** Fill in the blanks with correct words.

- i. An \_\_\_\_\_ of ants.
- ii. A \_\_\_\_\_ of bees.
- iii. A \_\_\_\_\_ of birds.
- iv. A \_\_\_\_\_ of grapes.

**Q2.** Match the following.

- |                               |   |                            |
|-------------------------------|---|----------------------------|
| i. Trumpet                    | - | two to four hours in a day |
| ii. An adult elephant can eat | - | group of elephants         |
| iii. Elephants sleep for      | - | sound of elephants         |
| iv. Herd                      | - | 105 kg of leaves           |

**Q3.** Fill in the blanks.

- i. Animals in herd usually move around together, searching for \_\_\_\_\_.
- ii. Male elephants live in the herd till they are \_\_\_\_\_ years old.
- iii. An egret eats insects from the skin of \_\_\_\_\_.
- iv. \_\_\_\_\_ is the oldest in the herd of elephants.

**Q4.** Answer the following in 20-30 words

- i. Name four animals which live in herds.
- ii. Which animal do we use for carrying loads?
- iii. Why do elephants love to play in mud and water?

**Q5.** Answer the following questions in 50-60 words.

- i. How do elephants feel when they are kept in chains? Discuss and share your feelings.
- ii. Write any three good points of living in a group.
- iii. Nandu did things that he liked to do, If you could spend a whole day with your friends, What all would you do?

**SANT NIRANKARI PUBLIC SCHOOL, TILAK NAGAR**  
**ENVIRONMENTAL STUDIES**  
**SESSION 2020-2021**  
**CLASS-IV**  
**CHAPTER- A DAY WITH NANDU**  
**Assignment-4(MONTH-APRIL)**

**Q1.** Give one word.

- i. Favourite food of animals. \_\_\_\_\_
- ii. Approximate weight of a three month old baby elephant. \_\_\_\_\_
- iii. Mother's mother is called as \_\_\_\_\_
- iv. Elephants \_\_\_\_\_ work like fans.

**Q2.** Write true or false for the following statements.

- i. An elephant herd has mainly female and baby elephants. (    )
- ii. The oldest male elephant is the leader of a herd. (    )
- iii. A group of elephants is called as pack. (    )
- iv. Elephants feel sad when they are kept in chains. (    )

**Q3.** Match the following:-

- |            |   |
|------------|---|
| i. Snake   | a. Gutargoo Gutargoo                    |
| ii. Bear   | b. lives in basket, makes hissing sound |
| iii. Horse | c. dances and jumps in circus           |
| iv. Pigeon | d. lives in desert runs very fast       |
| v. Camel   | e. runs very fast                       |

**Q4.** Answer the following questions in 20-30 words.

- i. If you were nandu, and you lived in a herd, what kind of things would you do?
- ii. Who takes decisions in your family?
- iii. Which animals have you sat on? Write their names.

**Q5.** Answer the following questions in 50-60 words.

- i. Write five lines on one of your favourite animals.
- ii. Write any 3 bad points of living in a group.
- iii. Why do you think the egret is sitting on the buffalo?



**SANT NIRANKARI PUBLIC SCHOOL, TILAK NAGAR**  
**ENVIRONMENTAL STUDIES**  
**SESSION 2020-2021**  
**CLASS-IV**  
**CHAPTER- A BUSY MONTH**  
**Assignment-6(MONTH-APRIL)**

**Q1.** Fill in the blanks.

- i. \_\_\_\_\_ is the national bird of India.
- ii. It lays the biggest egg \_\_\_\_\_.
- iii. An owl sleeps during the \_\_\_\_\_ and awakes at \_\_\_\_\_.
- iv. Gijubhai lived in \_\_\_\_\_.

**Q2.** Write true or false for the following statements.

- i. The robin is like the crow. (     )
- ii. Birds use the nest only to lay eggs. (     )
- iii. Cats have sharp teeth for tearing and cutting meat. (     )
- iv. Snakes always swallow their food whole. (     )

**Q3.** Define the following.

- i. Binoculars
- ii. Nest
- iii. Swallow

**Q4.** Answer the following questions in 20-30 words.

- i. How many times in one hour do the birds come to the nest?
- ii. If there are chicks in the nest, what do the parent birds bring for them to eat?
- iii. Do you know of any other bird that makes its nest in a tree trunk like the barbet does?

**Q5.** Draw a diagram of the following birds.

- i. Peacock
- ii. Parrot
- iii. Sparrow



**SANT NIRANKARI PUBLIC SCHOOL, TILAK NAGAR**  
**ENVIRONMENTAL STUDIES**  
**SESSION 2020-2021**  
**CLASS-IV**  
**CHAPTER- THE STORY OF AMRITA**  
**Assignment-7(MONTH-APRIL)**

**Q1.** Fill in the blanks.

- i. Khejadi village is near Jodhpur in \_\_\_\_\_.
- ii. We cannot survive without \_\_\_\_\_ and \_\_\_\_\_.
- iii. Children play for hours in the \_\_\_\_\_ of the trees.
- iv. People of Amrita's village are called \_\_\_\_\_.

**Q2.** Write true or false for the following statements.

- i. Many people including Amrita and her daughters died to save trees. (    )
- ii. Birds like sparrows and mynah are decreasing in urban areas. (    )
- iii. Plants and animals cannot survive without us. (    )
- iv. Amrita would greet her friend trees in the morning. (    )

**Q3.** Match the following.

- |                  |   |                   |
|------------------|---|-------------------|
| i. Strangers     | - | a. Desert area    |
| ii. Khejadi tree | - | b. Axes           |
| iii. Trees       | - | c. Dairy products |
| iv. Animals      | - | d. Oxygen         |

**Q4.** Answer the following questions in 20-30 words.

- i. What did the elders of khejadi village used to say?
- ii. What was special about the people of khejadi village?
- iii. Why do people hurt?

**Q5.** Draw a diagram of a tree and label its parts.

**SANT NIRANKARI PUBLIC SCHOOL, TILAK NAGAR**  
**ENVIRONMENTAL STUDIES**  
**SESSION 2020-2021**  
**CLASS-IV**  
**CHAPTER- THE STORY OF AMRITA**  
**Assignment-8(MONTH-APRIL)**

**Q1.** Choose the correct answer.

- i. \_\_\_\_\_ tree is found in desert areas
  - a. Neem
  - b. Khejadi
- ii. The strangers had \_\_\_\_\_ with them.
  - a. Gifts
  - b. Axes
- iii. The wood was needed for building the \_\_\_\_\_.
  - a. King palace
  - b. Amrita's house
- iv. The bark of khejadi tree is used for making.
  - a. Chocolates
  - b. Medicines

**Q2.** Fill in the blanks.

- i. King ordered that from now no \_\_\_\_\_ would be cut.
- ii. Sometimes back a film actor faced legal action for hurting \_\_\_\_\_.
- iii. There are \_\_\_\_\_ against hunting of some animals.
- iv. The \_\_\_\_\_ take care of the trees.

**Q3.** Define the following.

- i. Hunting
- ii. Strangers
- iii. Deforestation
- iv. Beautiful

**Q4.** Answer the following questions in 20-30 words

- i. Do you think we could survive if there were no trees and no animals?
- ii. Name two trees which you see a lot in your area.
- iii. Do the flowers remain on the tree throughout the year?

**Q5.** Answer the following questions in 50-60 words.

- i. People can be punished for hunting. Why do you think there is this punishment?
- ii. The number of birds are reducing due to changes in the environment. Discuss.
- iii. What is the importance of trees in our life?

**SANT NIRANKARI PUBLIC SCHOOL, TILAK NAGAR**  
**ENVIRONMENTAL STUDIES**  
**SESSION 2020-2021**  
**CLASS-IV**  
**CHAPTER- ANITA AND THE HONEYBEES**  
**Assignment-9(MONTH-APRIL)**

**Q1.** Choose the correct answers.

- i. Ants have \_\_\_\_\_ legs.
  - a. Four
  - b. Six
- ii. \_\_\_\_\_ Bee lays eggs in hive.
  - a. Queen
  - b. Male
- iii. What kind of eatables attract ants?
  - a. Sour
  - b. sweet
- iv. \_\_\_\_\_ Ants guard the nest.
  - a. Worker
  - b. Soldier

**Q2.** Fill in the blanks.

- i. Every child has the \_\_\_\_\_ to free education up to class VIII.
- ii. \_\_\_\_\_ Bees have no special role as worker.
- iii. Worker bees collect \_\_\_\_\_ from one flower to another.
- iv. Worker bees make the \_\_\_\_\_ and look after the \_\_\_\_\_ bees.
- v. \_\_\_\_\_ eatables attract ants.

**Q3.** Match the following.

- i. Honey bee sting
- ii. Buzz
- iii. February
- iv. October to December
- a. Sound of honey bee
- b. Litchi tree comes to flowers
- c. Pains a lot
- d. Honey bees lay their eggs

**Q4.** Answer the following questions in 20-30 words

- i. Why do insects come to the flowers?
- ii. What do people put on the part of the body where the bee has stung?
- iii. What kind of eatables attract ants? List them.

**Q5.** Answer the following questions in 50-60 words.

- i. Draw a picture of a honeybee.
- ii. Draw the picture of any two insects and name them.
- iii. Every child has a right to free education upto class VIII. Discuss.

**SANT NIRANKARI PUBLIC SCHOOL, TILAK NAGAR**  
**ENVIRONMENTAL STUDIES**  
**SESSION 2020-2021**  
**CLASS-IV**  
**CHAPTER- ANITA AND THE HONEYBEES**  
**Assignment-10(MONTH-APRIL)**

**Q1.** Give one word.

- i. When do honey bees lay their eggs? \_\_\_\_\_
- ii. Name two insects that you see near flowers. \_\_\_\_\_
- iii. What did Anita do to learn bee keeping? \_\_\_\_\_
- iv. Anita wants to become a \_\_\_\_\_.

**Q2.** Write true or false for the following statements.

- i. Queen ant lays eggs. ( )
- ii. Soldier ants do not look after and guard the ant's nest. ( )
- iii. It is the right of every child to go to school. ( )
- iv. Worker ants are always busy looking for food and bringing it to nest. ( )

**Q3.** Match the following.

- |               |                    |
|---------------|--------------------|
| i. Anita      | a. School          |
| ii. Dream     | b. Education       |
| iii. Right to | c. Syrup           |
| iv. Bees      | d. Bochaha village |

**Q4.** Answer the following questions in 20-30 words.

- i. Like honeybees, which other insects live together in a group?
- ii. What are the different colours of honey that you have seen?
- iii. For what purpose, honey is used in your house?

**Q5.** Answer the following questions In 50-60 words.

- i. Draw an ant and colour it.
- ii. Which was the best time to start bee keeping?
- iii. Explain the role of a wholesaler.

# संत निरंकारी पब्लिक विद्यालय कक्षा – चतुर्थ

## अभ्यास—पत्रक 1 (अपठित गद्यांश)

### प्र० 1 निम्नलिखित गद्यांश को पढ़कर पूछे गए प्रश्नों के उत्तर दीजिए—

मैं रूपया हूँ। मुझे सारी दुनिया प्यार करती है। मैं भोजन खरीदकर देता हूँ। भोजन से शरीर का पोषण होता है तथा पेट की भूख मिटती है। इस तरह मैं जीवनदान देता हूँ। मैं वस्त्र खरीदकर देता हूँ। वस्त्र पहनने से शरीर की सर्दी और गर्मी से रक्षा होती है। मैं रहने के लिए मकान खरीदकर देता हूँ। मनुष्य के आराम और सुख की अनेक वस्तुएँ खरीदकर देता हूँ। मुझे प्राप्त करने के लिये लोग कठिन से कठिन परिश्रम करते हैं।

- (क) भोजन क्या काम करता है?
- (ख) रूपया हमें क्या-क्या खरीदकर देता है?
- (ग) वस्त्र किससे हमारी रक्षा करते हैं?
- (घ) रूपया प्राप्त करने के लिये लोग क्या करते हैं?
- (ङ) इस गद्यांश का उचित शीर्षक लिखो ।

### प्र० 2 निम्नलिखित गद्यांश को पढ़कर पूछे गए प्रश्नों के उत्तर दीजिए—

हम जिस देश में रहते हैं, उसका नाम भारतवर्ष है। इसे हिंदुस्तान एवं इंडिया के नाम से भी जाना जाता है। हमारे देश की राजधानी नई दिल्ली है। हमारे देश में 29 राज्य और 7 केंद्रशासित राज्य हैं। "हिन्दी" हमारे देश की राष्ट्रभाषा है। गंगा, यमुना, गोमती, गोदावरी आदि हमारे देश की प्रमुख नदियाँ हैं। दिल्ली, कोलकाता, चेन्नई और मुंबई हमारे देश के प्रमुख बड़े नगर हैं। हमारे देश के उत्तर में हिमालय पर्वत है। वह रडार की भाँति हमारे देश की रक्षा करता है। देश के दक्षिण में हिंद महासागर इसके चरणों को निरंतर धोता रहता है।

- (क) हमारे देश का क्या नाम है। इसकी राजधानी कहाँ है?
- (ख) भारतवर्ष के अन्य नाम कौन-कौन से हैं?
- (ग) हमारी राष्ट्रभाषा का क्या नाम है?
- (घ) हमारे देश के दक्षिण में क्या है?
- (ङ) इस गद्यांश का उचित शीर्षक लिखिए

## अभ्यास—पत्रक 2(हमारी वर्णमाला)

प्र०1 दिए गए द्वित्व व्यंजन व संयुक्त वर्ण से दो-दो शब्द बनाओ

- (क) ज्ज - .....  
(ख) म्म - .....  
(ग) त्त - .....  
(घ) टट् - .....  
(ङ) क्ख - .....  
(च) व्य - .....

प्र०2 नीचे लिखे वर्णों को जोड़कर शब्द बनाओ ।

- (क) ब् + इ + ल् + ल् + ई .....  
(ख) व् + य् + अ + क् + त् + इ .....  
(ग) ग् + उ + ल् + आ + ब् + अ .....  
(घ) ग् + अ + द् + य् + आ .....  
(ङ) व् + इ + द् + य् + आ .....

## अभ्यास—पत्रक 3 (विलोम शब्द)

प्र०1 दिए गए शब्दों के विलोम शब्द लिखो ।

- |     |        |       |
|-----|--------|-------|
| (क) | कठिन   | ..... |
| (ख) | प्रश्न | ..... |
| (ग) | कठोर   | ..... |
| (घ) | सुख    | ..... |
| (ङ) | अमीर   | ..... |
| (च) | हार    | ..... |
| (छ) | सच     | ..... |
| (ज) | गुण    | ..... |
| (झ) | अँधेरा | ..... |
| (ञ) | मित्र  | ..... |

## अभ्यास—पत्रक 4 (लिंग बदलो )

प्र० 1 दिए गए शब्दों के लिंग बदलो ।

- |     |       |       |
|-----|-------|-------|
| (क) | हाथी  | ..... |
| (ख) | सेवक  | ..... |
| (ग) | शिष्य | ..... |
| (घ) | नर    | ..... |
| (ङ) | नौकर  | ..... |
| (च) | हिरन  | ..... |
| (छ) | लेखक  | ..... |
| (ज) | बकरा  | ..... |
| (झ) | लड़का | ..... |
| (ञ) | नाग   | ..... |



## अभ्यास—पत्रक 5 (वचन बदलो)

प्र० 1 वाक्यों में आए रेखांकित बहुवचन शब्दों के एकवचन लिखो।

वाक्य	एकवचन
(क) धोबी <u>कपडे</u> धो रहा है।	.....
(ख) मेज़ पर <u>संतरे</u> रखे हैं।	.....
(ग) आसमान में <u>पतंगे</u> उड़ रही हैं।	.....
(घ) मुझे <u>खिलौनों</u> के साथ खेलना अच्छा लगता है।	.....
(ङ) कक्षा में <u>लड़के</u> शोर मचा रहे हैं।	.....
(च) माँ से <u>डिब्बियाँ</u> खो गईं।	.....
(छ) <u>मछलियाँ</u> तैर रही हैं।	.....

प्र० 2 दिए गए वाक्यों के वचन बदलकर पुनः लिखो।

(क) चिड़िया दाना चुग रही है।	.....
(ख) कौआ रोटी खा रहा है।	.....
(ग) मेज़ पर केला रखा है।	.....
(घ) कपड़ा धुल गया है।	.....
(ङ) लड़की पढ़ रही है।	.....

## अभ्यास—पत्रक 6 (क्रिया तथा काल)

प्र० 1 दी गई धातुओं की उचित क्रियाएँ बनाकर रिक्त स्थानों की पूर्ति कीजिए ।

आएगी, कर, पढ़, आ, जा, चर

- (क) शायद कल गीता भी ..... ।  
(ख) हम सभी कल सर्कस देखने ..... ।  
(ग) अध्यापिका ..... रही है।  
(घ) प्रातः काल व्यायाम ..... स्वास्थ्य के अच्छा है।  
(ङ) गाय घास ..... है।  
(च) अध्यापिका छात्रों को प्रदर्शनी दिखाने ले गई।

प्र० 2 निम्नलिखित वाक्यों में क्रिया का काल पहचानकर दिए गए स्थान में लिखिए।

काल

- (क) परीक्षाएँ आने वाली हैं। .....  
(ख) मीरा प्रेम दीवानी थी .....  
(ग) गाड़ी निकल चुकी होगी .....  
(घ) प्रेमचंद ने अनेक कहानियाँ लिखीं। .....  
(ङ) मैं चाय नहीं पी पाऊँगाँ। .....

## अभ्यास—पत्रक 7 (संज्ञा)

प्र० 1 दिए गए वाक्यों में से संज्ञा शब्द छाँटकर लिखो।

(क) माँ बाज़ार से फल लाई।

.....

(ख) भारत का तिरंगा सबसे प्यारा है।

.....

(ग) लालकिला दिल्ली में स्थित है।

.....

(घ) मुंबई सुंदर शहर है।

.....

(ङ) मेरा विद्यालय सबसे अच्छा है।

.....

प्र० 2 निम्नलिखित संज्ञा शब्दों के सामने उनके भेद लिखो।

(क) प्रेम

.....

(ख) मछली

.....

(ग) हिमालय

.....

(घ) मिठास

.....

(ङ) राहुल

.....

(च) अध्यापक

.....

(ज) बचपन

.....

(ञ) वीरता

.....

## अभ्यास—पत्रक 8 (सर्वनाम)

प्र० 1 बाक्स में से छँटकर दिए गए रिक्त स्थानों में उचित सर्वनाम लिखो।

हम, उन्ही, कहाँ, उसने, मेरा, उसकी, वह, उसके, यह, मैंने, मेरे

राहुल ..... मित्र है। ..... माँ अध्यापिका तथा .....  
पिताजी डॉक्टर हैं। ..... पढ़ने में बहुत होशियार है। ..... पूछा .....  
..... वाद— विवाद प्रतियोगिता ..... होगी। ..... कहा .....  
माँ अध्यापिका हैं आओ ..... दोनों ..... से पूछें।

प्र० 2 सही सर्वनाम का प्रयोग करके वाक्य दोबारा लिखिए—

क) कल तुम के घर कौन आया था ?

.....

(ख) मैंने मेरी साइकिल रख दी है।

.....

(ग) अब्दुल मेरा भाई है अब्दुल दिल्ली में रहता है।

.....

(घ) दरवाजे पर कुछ खड़ा है।

.....

## अभ्यास – पत्रक-9 (विशेषण)

प्र० 1 इन वाक्यों में आए विशेषण शब्द को छाँटकर लिखों

वाक्य	विशेषण शब्द
(क) लंबा कोट और ऊँचे जूते मत पहनो।	.....
(ख) चार लीटर दूध भी लेते आना।	.....
(ग) दयालु मालिक और मेहनती नौकर कहाँ मिलते हैं।	.....
(घ) कुछ फूल भी लेते आना।	.....
(ङ) वह लड़की भी पहाड़ पर चढ़ेगी।	.....

प्र० 2 इन वाक्यों में से विशेषण और विशेष्य शब्द छाँटकर लिखों

वाक्य	विशेषण	विशेष्य
(क) मीरा ने मधुर गीत गाया	.....	.....
(ख) कुछ लोग सैर कर रहे हैं।	.....	.....
(ग) आपके पिताजी आए हैं।	.....	.....
(घ) दो मीटर कपड़ा रमा को भी दो।	.....	.....
(ङ) मेरी नीली कमीज़ कहाँ है।	.....	.....

## अभ्यास – पत्रक-10 (विराम चिह्न)

प्र० 1 उचित विराम चिह्न लगाकर वाक्य दोबारा लिखिए-

क) मैं कल भात खाऊँगा आप क्या खाएँगे

.....

(ख) माँ ने कहा विद्यालय समय पर पहुँच जाना

.....

(ग) अरे आप इतनी जल्दी क्यों आ गए

.....

(घ) गंगा मोना राहुल और श्याम भी खेलने जाएँगे

.....

प्र० 2 निम्नलिखित विराम चिह्नों के लिए उचित वाक्य लिखिए-

क) अल्प विराम

.....

(ख) प्रश्नसूचक चिह्न

.....

(ग) उदाहरण चिह्न

.....

(घ) योजक चिह्न

.....

(ङ) विस्मयसूचक चिह्न

.....

**SANT NIRANKARI PUBLIC SCHOOL, TILAK NAGAR**  
**ASSIGNMENT – 1 (APRIL 2020 – 2021)**  
**SUBJECT - MATHEMATICS**  
**CLASS: IV**  
**LESSON: FRACTIONS**

1. Write the fraction representing the shaded portion.

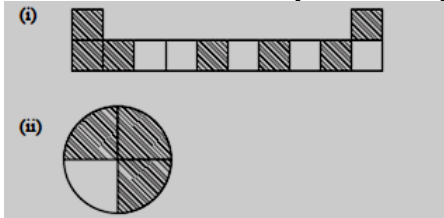

1. Colour the part according to given fraction :

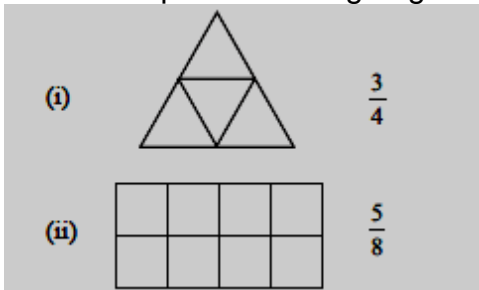

2. Which of the following represent  $\frac{1}{2}$  ?



- (i) Only figure (a)
- (ii) Only figure (b)
- (iii) Both figures (a) and (b)
- (iv) Neither figure (a) nor figure (b)

3. Fill in the blanks by using  $>$ ,  $<$  or  $=$  in the following to make correct statements

a)  $\frac{5}{8} \square \frac{7}{8}$

b)  $\frac{5}{21} \square \frac{7}{7}$

c)  $\frac{2}{3} \square \frac{10}{15}$

4. Shade the figures for the fraction given below it.

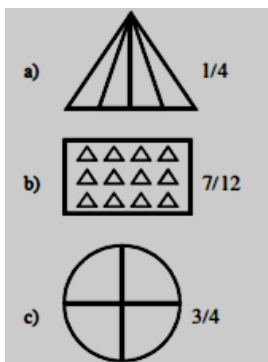

5. Write natural numbers from 1 to 15 : \_\_\_\_\_

- (i) What fraction of them are prime numbers?
- (ii) What fraction of them are composite numbers?

6. Identify the following fractions :

- (i) 6 hours of a day.
- (ii) 750 gms of a kilogram.

7. Find the equivalent fractions of the following fractions:

a.  $\frac{3}{4}, \frac{4}{5}, \frac{6}{11}$  with numerator 36

b.  $\frac{6}{16}, \frac{20}{32}, \frac{80}{128}$  with denominator 8

8. Reduce the following fractions in simplest form;

$\frac{28}{98}, \frac{169}{221}$

9. A shopkeeper had 30 oranges, 50 apples and 80 bananas. He sold 15 oranges, 25 apples and 40 bananas. What fraction of each fruit was left?

10. Fill the correct number in the boxes:

a.  $\frac{1}{3} = \frac{2}{\quad} = \frac{3}{\quad} = \frac{\quad}{12} = \frac{\quad}{15} = \frac{\quad}{18} = \frac{10}{\quad}$

b.  $\frac{5}{6} = \frac{10}{\quad} = \frac{30}{30} = \frac{\quad}{\quad} = \frac{15}{\quad} = \frac{35}{\quad}$

11. Find which is larger;

a.  $\frac{3}{7}$  or  $\frac{4}{9}$                       b.  $2\frac{5}{6}$  or  $3\frac{3}{4}$

12. Write the following fractions in ascending order:

a.  $\frac{3}{11}, \frac{3}{5}, \frac{3}{9}, \frac{3}{13}, \frac{3}{21}, \frac{3}{20}$                       b.  $\frac{2}{3}, \frac{1}{2}, \frac{4}{5}, \frac{1}{13}, \frac{3}{10}$

13. Convert the following improper fractions to mixed fractions:

(i)  $\frac{29}{6}$                       ii.  $\frac{43}{8}$

14. Abhinav poured  $3\frac{3}{4}$  litres of water into a bucket. Later he poured  $\frac{2}{5}$  litres out of the bucket. How much water is left in the bucket?



**SANT NIRANKARI PUBLIC SCHOOL, TILAK NAGAR**  
**ASSIGNMENT – 2 (APRIL 2020 – 2021)**  
**SUBJECT - MATHEMATICS**  
**CLASS: IV**  
**LESSON: DECIMALS**

**OBJECTIVE (1-6)**

1. Write each of the following as decimals :
  - a. Three tens and 8 tenths \_\_\_\_\_
  - b. Three hundred four and five hundredths \_\_\_\_\_
  - c. Thirty and one tenth \_\_\_\_\_
  - d. Sixty point two seven six \_\_\_\_\_
  
2. Convert the following decimals into lowest form of fractions :
  - a. 4.5 \_\_\_\_\_
  - b. 3.8 \_\_\_\_\_
  - c. 7.0 \_\_\_\_\_
  
3. Which is greater?
  - a) 5.31 or 5.28 \_\_\_\_\_
  - b) 6.321 or 6.312 \_\_\_\_\_
  
4. Which whole number is nearer to the following?
  - a) 4.6 \_\_\_\_\_
  - b) 0.99 \_\_\_\_\_
  
5. State True Or False:
  - a.  $3.03 + 0.016 = 3.019$
  - b.  $42.28 - 3.19 = 39.09$
  - c.  $19.25 < 19.053$
  - d.  $13.730 = 13.73$

**SUBJECTIVE QUESTIONS**

1. Express as rupees using decimals :
  - (i) 60 paise \_\_\_\_\_
  - (ii) 825 paise \_\_\_\_\_
2. Express as km using decimals :
  - (i) 7 mm \_\_\_\_\_
  - (ii) 32 km 51m \_\_\_\_\_
  
3. Add :  $15.07 + 10.252 + 6.8$
4. Subtract :  $18.728 - 9.97$
5. Raghu got ₹500 and he spent ₹118 on stationary items and ₹50.75 on eatables. Find the money left with Raghu.
6. Rina bought 4 kg 500 g of rice, 3 kg 400 g of dal and 1 kg 250 g of sugar. Find the total weight of all the items she bought.
7. Write 1.284 in words.

8. Write the following decimals in the place value chart :

(i) 158.42 (ii) 101.056 (iii) 0.496

9. Write the following as decimals:

a.  $\frac{158}{10}$

b.  $36\frac{4}{10}$

c.  $300+5+\frac{8}{10}$

d.  $20+4+\frac{3}{10}$

10. Express the following as decimals by converting the denominator 10,100, 1000:-----

a.  $\frac{7}{5}$

b.  $\frac{17}{50}$

c.  $\frac{39}{200}$

d.  $\frac{18}{25}$

**SANT NIRANKARI PUBLIC SCHOOL, TILAK NAGAR**  
**ASSIGNMENT – 3 (APRIL 2020 – 2021)**  
**SUBJECT - MATHEMATICS**  
**CLASS: IV**  
**LESSON: GEOMETRY AND TIME**

Q.1 Which two -dimensional figure has 4 corners?

- a) Triangle
- b) Square
- c) Circle
- d) Pentagon

Q.2 Identify the 3 - D shape ?



- a) Cone
- b) Cube
- c) Cuboid
- d) Pyramid

Q.3) Classify the angles as acute, obtuse or right.

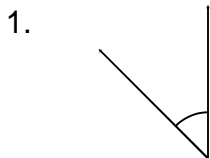

\_\_\_\_\_

|

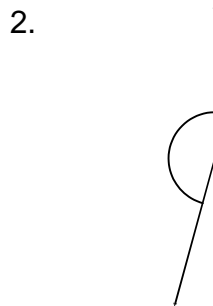

\_\_\_\_\_

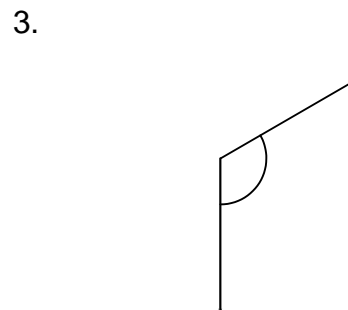

\_\_\_\_\_

Q.4) The longer hand in the clock is called ?

Q.5) When short hand is at 3 and long hand is at 12 then time is ?

Q.6) 2 hours 30 minutes = \_\_\_\_\_ Minutes

Q.7) The number of days in 8 week is \_\_\_\_

Q.8) Leap year come after every \_\_\_\_ Years.

Q.9) How many seconds are there in 30 minutes?

Q.10) 6 minute = \_\_\_\_ seconds

Q.11) A bus leaves for Rampur at 4:30 p.m. It takes 1 hr. 25 min. to reach there. At what time will it reach at Rampur?

Q.12) The duration of a film show is 3 hr. 15 min. It starts at 6:30 p.m. When will it end?

Q.13) The Punjab Mail arrived at Lucknow at 11:55 a.m. It reached at Lucknow 1 hr. 25 min. late. What is the scheduled arrival time of the train at Lucknow?

Q.14) Rex visited a fashion show. He stayed there for 2 hr. 30 min. and came back at home. If he reached in the fashion show at 8:45 p.m. when did he leave for his home?

Q.15) Max travelled 2 hr. 45 min. by bus and 4 hr. 45 min. by train. Calculate the time he spent in travelling.

**SANT NIRANKARI PUBLIC SCHOOL, TILAK NAGAR**  
**ASSIGNMENT – 4 (APRIL 2020 – 2021)**  
**SUBJECT - MATHEMATICS**  
**CLASS: IV**  
**LESSON: MEASUREMENT**

**Q1.** Which unit is appropriate to measure the following:

- i) Distance between Agra and Delhi
- ii) Length of a 100 Rupee note
- iii) Length of your Maths book
- iv) Height of a Building
- v) Width of a table
- vi) Length of a play ground

**Q2.** Find the sum:

- i) 9m 35 cm and 18m 39 cm
- ii) 152km 320m and 7 km 6m

**Q3.** Subtract the following:

- i) 6km 578 m from 15km
- ii) 13km 230m from 42km 789m

**Q4.** Find the Product:

- i) 156km 210m by 12
- ii) 62m 15cm by 17

**Q5.** Divide and find the Quotient:

- i) 24km 96m by 12
- ii) 46m 75cm by 5

**Q6.** A cloth merchant sold 18m 68cm cotton and 45m 96cm silk cloth.  
How much total cloth did he sell?

- Q7.** A tailor uses 5m 20 cm of cloth for a suit. How much cloth will be required for 18 such suits?
- Q8.** Ram travelled 62 km 80m by car and 140 km 20 m by air. What distance did he travel in all?
- Q9.** 302m 13cm cloth is distributed among 9 persons. How much cloth will each person get?

**SANT NIRANKARI PUBLIC SCHOOL, TILAK NAGAR**  
**ASSIGNMENT – 5 (APRIL 2020 – 2021)**  
**SUBJECT - MATHEMATICS**  
**CLASS: IV**  
**LESSON: MONEY**

- Q.1) In India the unit of currency is
- Q.2)  $\frac{1}{5}$  of Rs. 1 = \_\_\_ Paise
- Q.3) How many 50 paise make ten rupee.
- Q.4) If one pen costs Rs. 29.00, what is the cost of 9 such pens?
- Q.5) If 8 cups cost Rs. 62.00 Find the cost of each cup
- Q.6) Akshat earns Rs. 325.50 per week how much does he earn each day
- Q.7) Punam's monthly salary is Rs.6000. What is her annual income?
- Q.8) 237 paise is equal to how many Rs?
- Q.9) Sumit purchased a shirt and gave 500 rupee note to the shopkeeper. He got 1 hundred rupee note and two twenty rupee notes back. What was the cost of the shirt?
- Q.10) Express the following amount of money in short form:
- (i) 35 rupees 25 paise
  - (ii) 45 paise
- Q.11) Write the following amounts of money in figures:
- (i) Ten rupees and thirty seven paise
  - (ii) Twenty five rupees and four paise
  - (iii) Eighty five paise
  - (iv) Sixty seven rupees
  - (v) One rupee and seventy five paise
- Q.12) Write the following amounts of money in words:
- (i) Rs. 5.75
  - (ii) Re. 0.09
- Q.13) Write the following amounts of money using decimal points:
- (i) 3 rupees 50 paise
  - (ii) 50 rupees 4 paise
- Q.14) Convert the following amounts into paise:
- (i) Rs. 5.25
  - (ii) Rs. 5.09
- Q.15) Convert the following amounts into rupees:
- (i) 945 paise
  - (ii) 870 paise

**SANT NIRANKARI PUBLIC SCHOOL, TILAK NAGAR**  
**ASSIGNMENT – 6 (APRIL 2020 – 2021)**  
**SUBJECT - MATHEMATICS**  
**CLASS: IV**  
**LESSON: MULTIPLICATION**

1. Find the product
  - i.  $78 \times 4$
  - ii.  $93 \times 40$
  - iii.  $115 \times 6$
2. The cost of one scooter is \$ 35,780. What will be the cost of 100 such scooters?
3. One cycle costs \$ 1,560. How much will be the cost of 12 such cycles?
4. A man has 715 notes of 500 rupees denomination. How much money does he possess?
5. How many seconds are there in a day? [1 day = 24 hours, 1 hour = 60 minutes, 1 minute = 60 seconds]
6. A factory produces 5,376 bulbs per month. What will be its yearly production of bulbs?
7. There are 1125 students in a school. If a student pays \$ 365 as fees and \$ 150 as bus charge per month, how much money is collected in a month?
8. The price of a mathematics book is \$ 65 and of a science book is \$ 78. Find the cost of 40 mathematics books and 115 science books in total?



**SANT NIRANKARI PUBLIC SCHOOL, TILAK NAGAR**  
**ASSIGNMENT – 7 (APRIL 2020 – 2021)**  
**SUBJECT - MATHEMATICS**  
**CLASS: IV**  
**LESSON: DIVISION**

1. *Divide and verify the result:*

(i)  $27 \div 9$

(ii)  $72 \div 9$

2. *Find the quotient and remainder if any:*

(i)  $53 \div 7$

(ii)  $27 \div 6$

3. *Fill in the gaps:*

(i)  $57 \div 1 = \underline{\hspace{2cm}}$  .

(ii)  $329 \div 1 = \underline{\hspace{2cm}}$  .

(iii)  $165 \div 165 = \underline{\hspace{2cm}}$  .

(iv)  $928 \div \underline{\hspace{2cm}} = 1$ .

(v)  $7314 \div \underline{\hspace{2cm}} = 7314$ .

(v)  $\underline{\hspace{2cm}} \div 152 = 0$ .

4. *Find the quotient and the remainder without dividing the dividend number:*

(i)  $763 \div 10$

(ii)  $3914 \div 10$

(iii)  $8326 \div 10$

(iv)  $307 \div 10$

(v)  $437 \div 100$

(vi)  $908 \div 100$

5. There are 1025 students in a school containing 25 sections. If in each section there are equal number of students, find their number in each section.

6. A train runs 5,580 kms in 36 hours. Find the speed of the train in km/hour.

7. If the quotient is 57, the divisor is 45 and the remainder is 29, find the dividend.

8. When 65 is multiplied by a number, the product is 5590. Find the number.

9. Divide the sum of 7,000 and 2,839 by 23.

**SANT NIRANKARI PUBLIC SCHOOL, TILAK NAGAR**  
**ASSIGNMENT – 8 (APRIL 2020 – 2021)**  
**SUBJECT - MATHEMATICS**  
**CLASS: IV**  
**LESSON: SUBTRACTION**

1. Which number should be subtracted from 52847 to get 22489?
2. A milk-dairy produces 25,545 litres of milk every day. It supplies 15,625 litres of milk to a milk-depot and the rest to the market. How much milk is supplied to the market?
3. There are 63,675 bags of wheat and rice together in the grain stock. The wheat bags are counted as 34,768 in number. Find the number of rice bags.
4. Sam had \$ 52,490. He purchased a cow for \$ 15,870 and a buffalo for \$ 25,785. How much money is with him now?
5. *Write in columns and subtract the following:*
  - i.  $5732 - 1813$
  - ii.  $9849 - 2721$
6. **Subtract:**
  - i. 474 from 563
  - ii. 149 from 327
  - iii. 362 from 548
7. Andy's friends had a book reading contest. Among the boys, Aaron read 4 books, Andrew read 7, Mandy read 2 and Andy read 12 books. Among the girls, Ashley read 11 books, Nancy read 2, Shelly read 7 and Michelle read 3.
  - i. How many books did the boys read?
  - ii. How many books did the girls read?
  - iii. Who read more books, the girls or the boys? How many more?
  - iv. How many more books did Aaron read than Michelle?
8. 24 girls and 15 boys from Andy's class issued books from the school library. How many more girls than boys got books from the library?

**SANT NIRANKARI PUBLIC SCHOOL, TILAK NAGAR**  
**ASSIGNMENT – 9 (APRIL 2020 – 2021)**  
**SUBJECT - MATHEMATICS**  
**CLASS: IV**  
**LESSON: ADDITION**

1. What is the sum of 40711 and 73412
2. Which number should be added to 25483 to get the sum of 65785?
3. Which is greater, 42929 or 91429 and by how much?
4. There are 35,278 students in Class III, 32,184 students in Class IV and 25,375 students in Class V in the schools of a city. Find the total number of students reading in Classes III, IV and V.
5. *Write in columns and add:*
  - i. 72956 and 62450
  - ii. 310572 and 576296
6. Fill in the blanks using properties of addition:  $23114 + (13445 + 16671) = ($   
\_\_\_\_\_  $+ 13445) + 16671$
7. Fill in the blanks using properties of addition:  $43594 + 24351 = 24351 +$   
\_\_\_\_\_
8. Fill in the blanks using properties of addition:  $25437 + 0 =$  \_\_\_\_\_
9. Tick the correct option: The sum of  $800 + 200$ 
  - i. 900.
  - ii. 1000.
  - iii. 1004.
  - iv. 600
10. There are 1276 red clips and 6754 white clips in a carton. What is the total number of clips in the carton
11. A factory produced 4560 bulbs in January and 3068 bulbs in February. How many bulbs they produced in two months?

**SANT NIRANKARI PUBLIC SCHOOL, TILAK NAGAR**  
**ASSIGNMENT – 10 (APRIL 2020 – 2021)**  
**SUBJECT - MATHEMATICS**  
**CLASS: IV**  
**LESSON: NUMBER SYSTEM**

1. Write the roman numeral of the following.
  - i. 75
  - ii. 100
  - iii. 101
  - iv. 67
2. How will the number 3,53,552 be written according to Indian System?
3. Write the following number using comma in International System of Numeration.  
645340001
4. Estimate the following (by rounding off to nearest tens):
  - i. 941
  - ii. 312
  - iii. 777
  - iv. 13
5. Solve the following:
  - i.  $X + V$
  - ii.  $V + III$
  - iii.  $XV + II$
  - iv.  $IX + IX$
  - v.  $II + VI$
  - vi.  $V - I$
  - vii.  $VII - IV$
  - viii.  $IX - III$
  - ix.  $XL - VII$
6. How many millions make a billion?
7. Write the smallest 3 digit number which does not change if the digits are written in reversed order.
8. Find the difference between the number 279 and that obtained on reversing its digits.
9. Write all possible 3-digit numbers using the digits 6,0,4 when repetition of digits is not allowed.
10. 1 Million = \_\_\_\_\_ Lakh
11. The Roman numeral for 100-61 is:-
12. The ascending order of 6411, 6144, 6344, 6744 is