

SANT NIRANKARI PUBLIC SCHOOL, TILAK NAGAR

HOLIDAYS HOMEWORK CLASS - PRE SCHOOL

SESSION: 2024-25

(SUMMER BREAK :- 20.05.2024-02.07.2024)



Summer, summer, I'm so glad you're here!

Summer, summer, Let's give a cheer!

Summer, summer, I'll meet you at the park

Summer, summer, Let's stay up till dark!

Dear Parents,

It's Summer time, when students can relax and enjoy their free time. It is a time to catch up on rest, spend time with family and friends, explore new hobbies and visit new places. Summer vacation brings a lot of fond memories. These vacations are the most fun period of the year.

As the school closes for summer break we have planned some activities for your child to enhance his / her learning skills in a fun filled way.

HOLISTIC DEVELOPMENT

It is very important for the holistic development of the child to learn and implement some basic etiquettes and manners in their day to day life. Kindly help your ward in learning basic things during the vacations that can assist our little students in their overall **PHYSICAL AND MENTAL DEVELOPMENT and make them independent.**

- **Brush your teeth twice a day.**
- **Take bath regularly.**
- **Wash your hand before and After every meal.**
- **Trim your nails regularly.**
- **Learn how to zip your school bag.**

- Learn how to button and unbutton the shirt.
- Learn taking self-care while using the washroom.
- Learn how to wear shoes and socks.

Politeness is the flower of humanity.

Kindly help your child to inculcate good habits and teach them to be polite and respectful:

- Always teach them to greet all elders in the morning.
- Use magic words like: SORRY, THANK YOU, PLEASE, WELCOME AND EXCUSE ME.
- Learn to listen.
- Let them take their own plates after every meal.
- Learn to listen patiently.

LIFE SKILLS

To develop “fine motor skills” let your child indulges in activities like:

- Turing the pages of book.
- Pasting and gluing.
- Eating with a fork or spoon.
- Mashing Potatoes.
- Shelling out Peas.
- Peeling fruit like banana.
- Settling the table.
- Turing the door knobs.
- Opening and closing of zippers
- Opening and closing of bottle cap / tiffin lid.

FATHER’S DAY CRAFT AND MAKE THEM FEEL SPECIAL.....

Father means:

Fantastic , adviser, teacher, hero, exceptional and remarkable.

On father’s day i.e. 18th June 2024 make your father feel very special by doing simple craft work with the help of your mother / sibling and click beautiful photographs and send it to your class teacher. Sharing below some craft samples

Make any one craft as per your choice and click the pictures with your dad and send the same to your class teacher. You can do more creative work as per your imagination.



INTERNATIONAL YOGA DAY (21ST JUNE 2024)

Yoga Day celebrations aim to create awareness about the holistic nature of yoga and encourage people to incorporate it into their daily lives for enhanced well-being.

Make your ward practice some simple yoga asana and encourage them to do the same on regular basis. Educate them about the benefits of yoga in daily life. Click the picture and share it with the class teacher.

REVISION TIME

It's time for fun filled activities so let's enjoy the summer time with some learning and enhance our gross and fine motor skills.

COLOR THE LANTERN AND USE SEQUENCES FOR DECORATION AND STICK PAPER RIBBONS ON TO THE BOTTOM OF THE LANTERN.

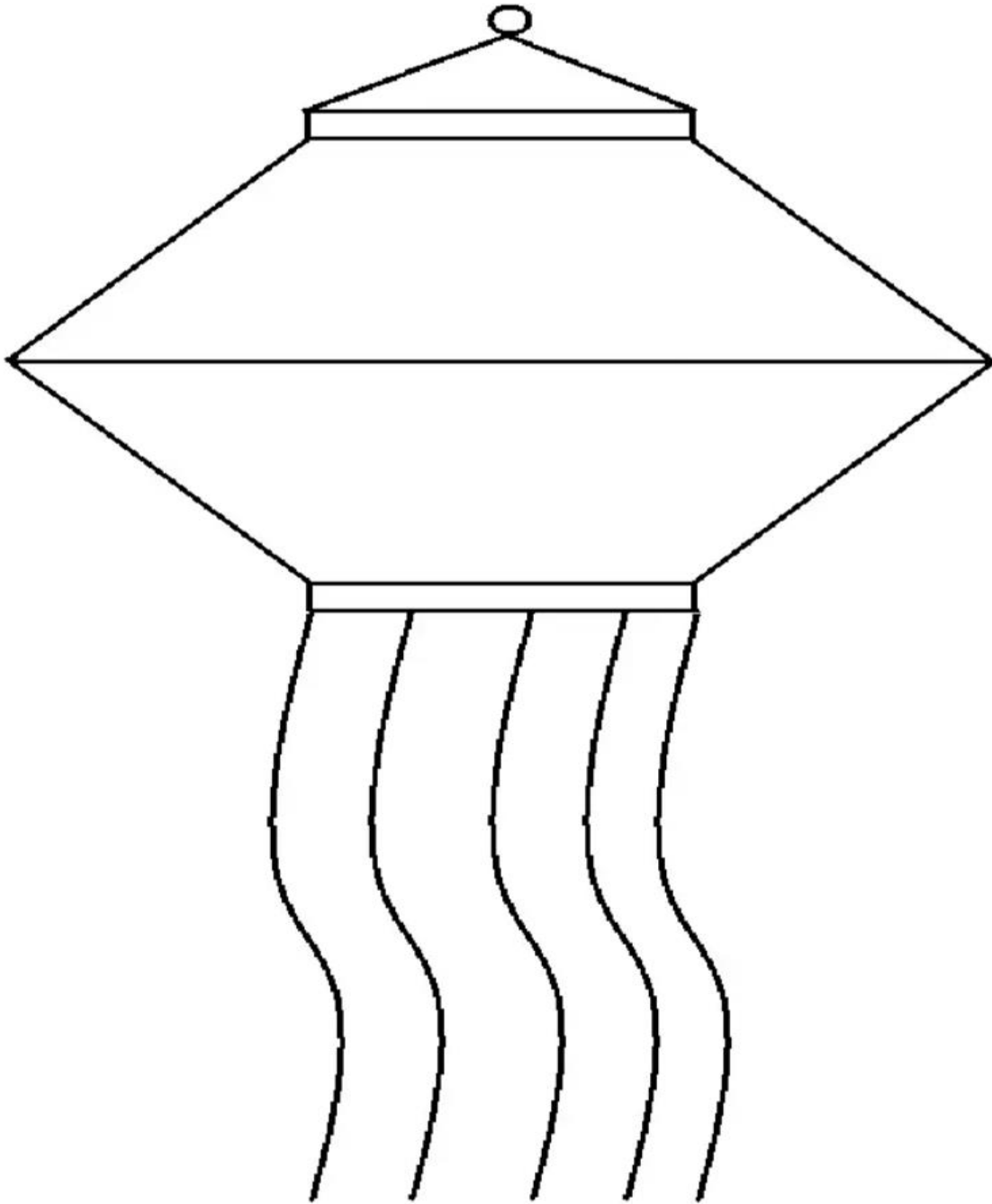

PUT MATCH STICKS OR ICE-CREAM STICKS ON TO THE SUN AND STICK COTTON ON THE CLOUDS.

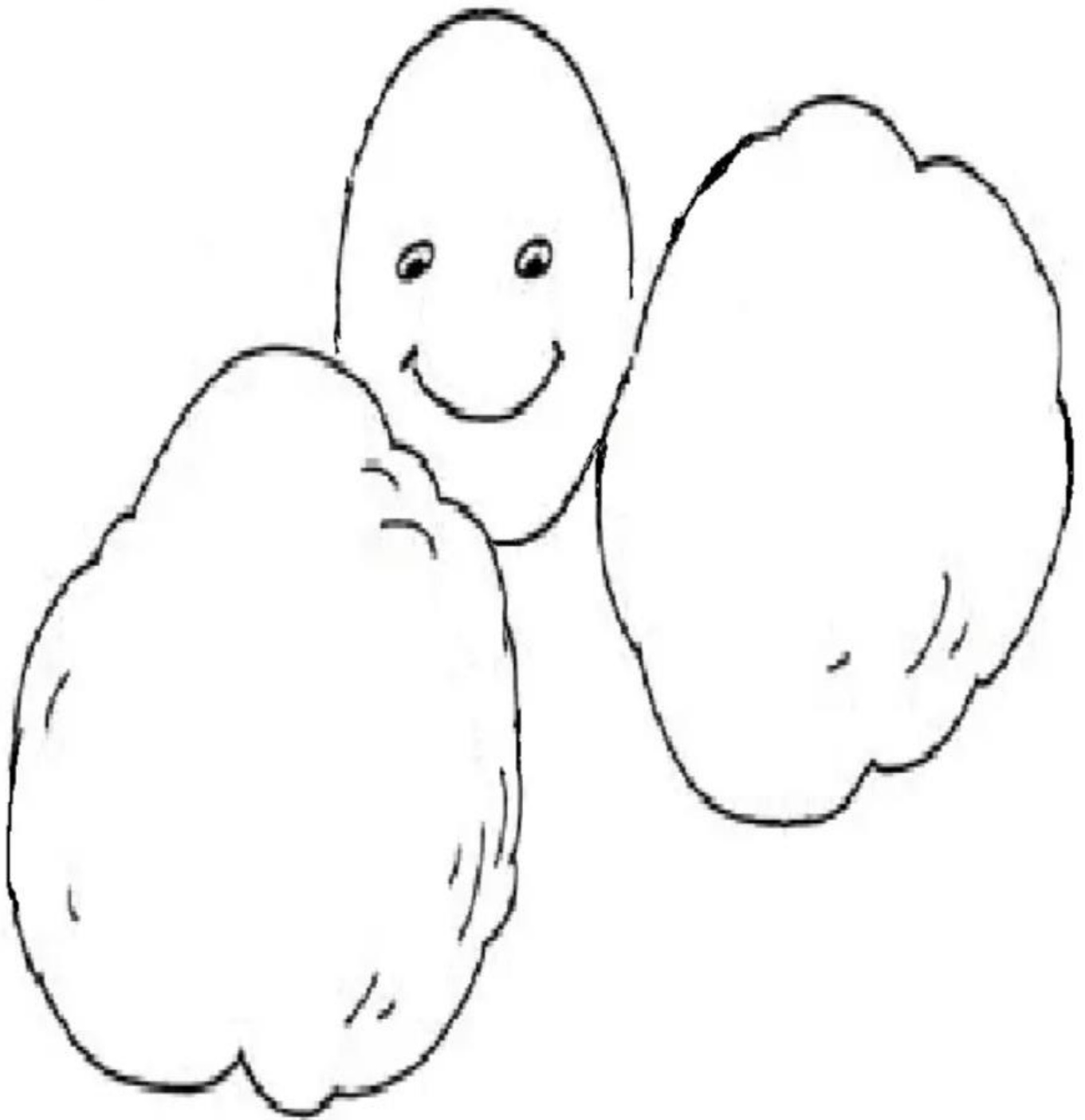

STICK DIFFERENT SIZE OF LEAVES ON TO THE OLD OAK TREE.



CUT PIECES OF BLACK WOOLEN THREAD, AND STICK IT IN CRIS CROSS
DIRECTION ON THE NET.

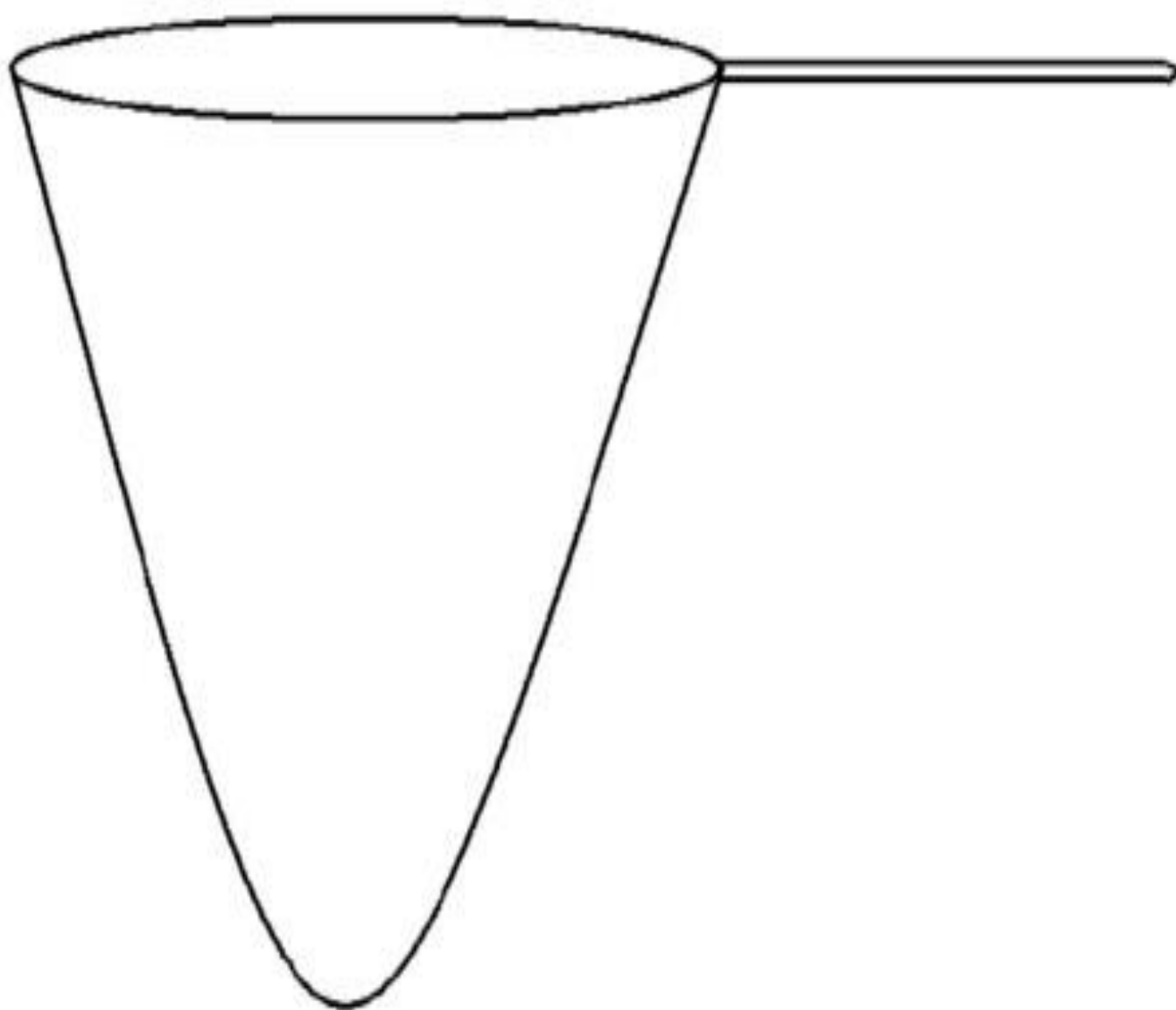

CRAFT COLLAGE: TEAR PIECES OF RED MARBLE PAPER, APPLY GLUE TO THE OUTLINE OF AN APPLE AND STICK RED PIECES OF PAPER ON IT.

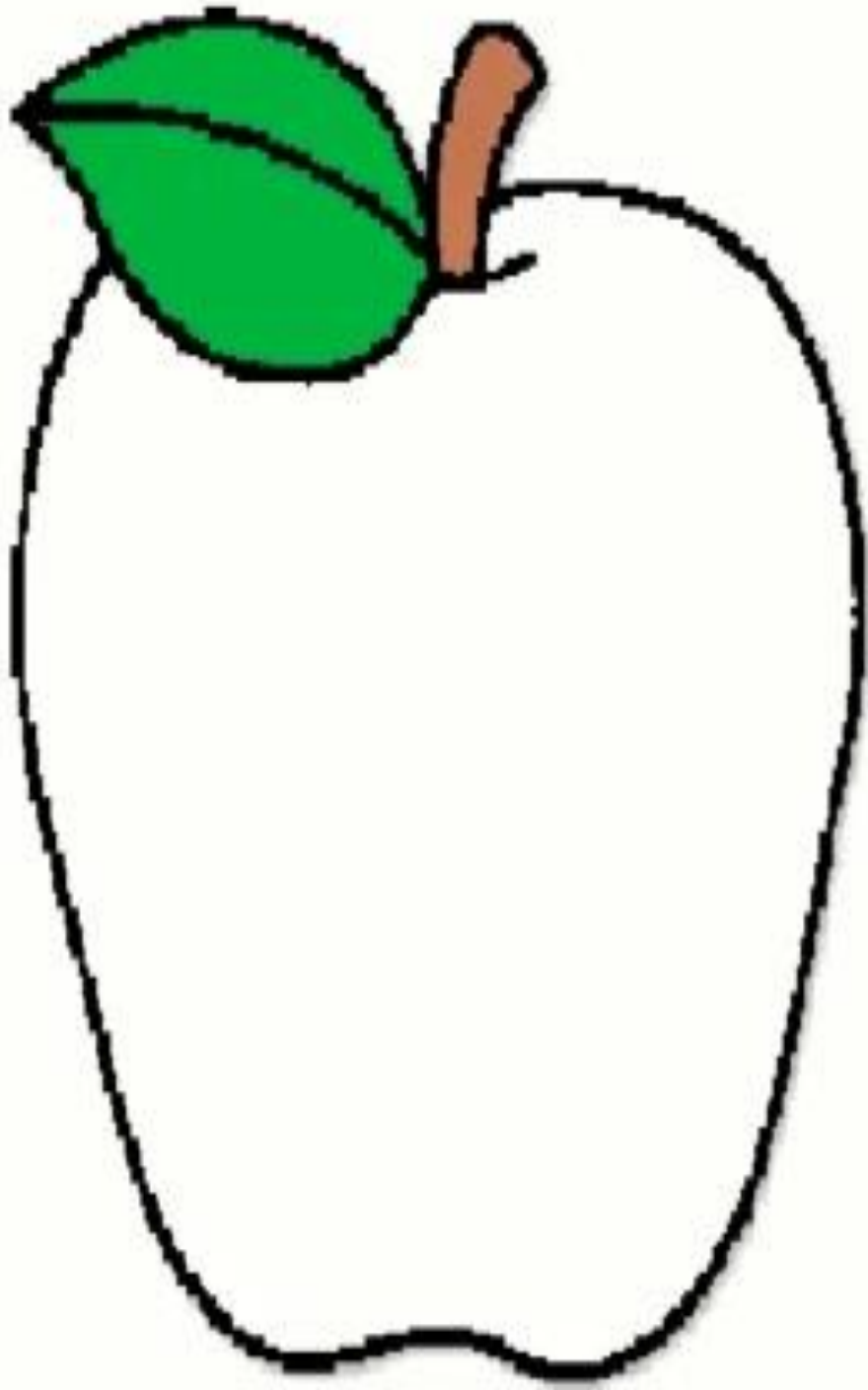

USE DIFFERENT SATIN RIBBON BY STICKING IT WITH FEVICOL AND MAKE
COLORS OF THE RAINBOW

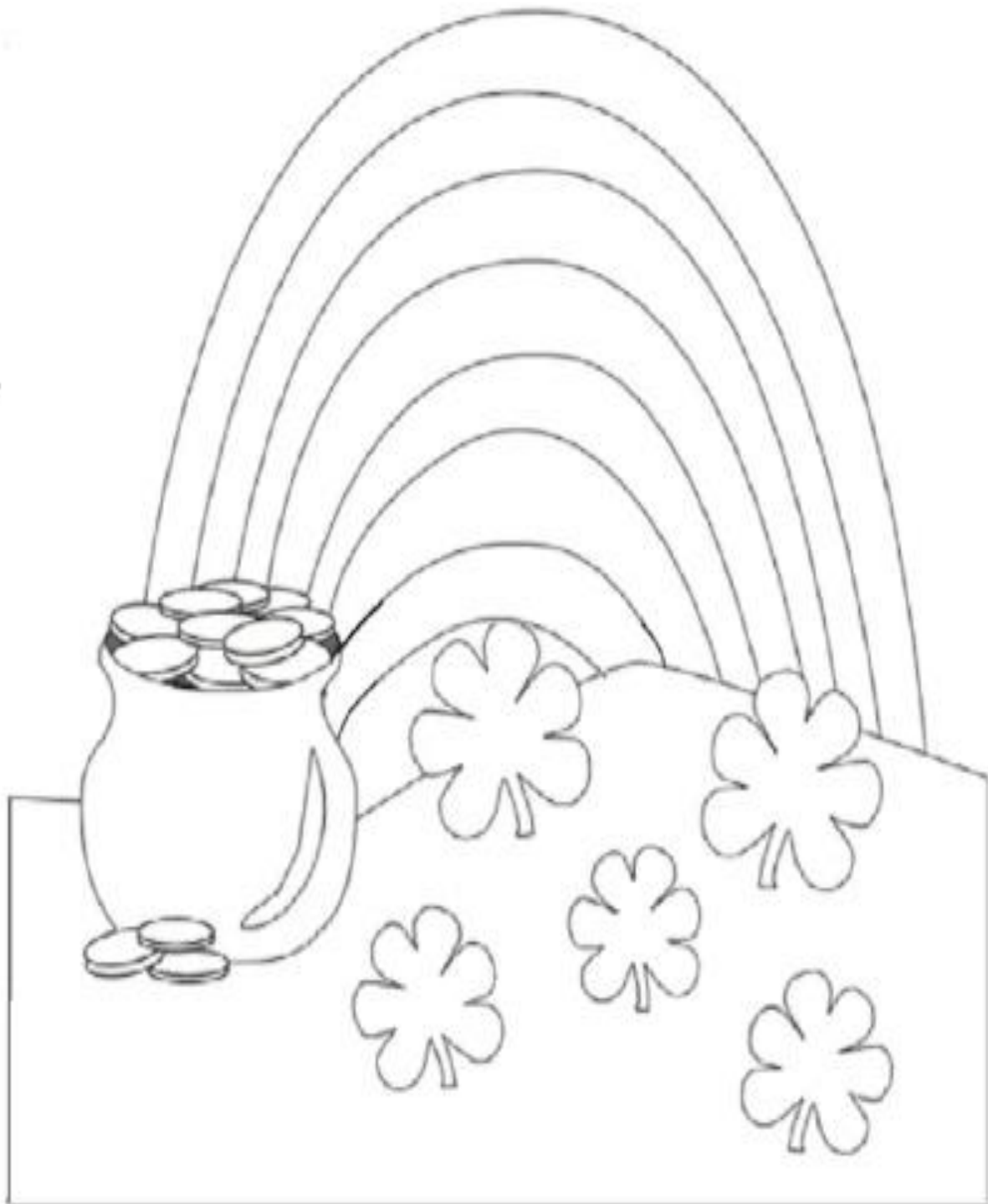

MAKE A BEAUTIFUL HANGING USING WASTE MATERIAL:



1. MAKE A SEPARATE NOTEBOOK (3 IN 1) AND DO THE FOLLOWING WORK IN IT: COVER IT WITH PINK SHEET
 - PRACTICE OF WRITING LETTERS DONE IN CLASS.
 - WRITTEN PRACTICE OF NUMBERS 1 TO 10.(2 TIMES)

NOTE: Make a handmade Folder and put all the worksheets in it.



#STAY SAFE

#HAPPY HOLIDAYS

The School will reopen on 03.07.2024 (Wednesday)